

CONSEW[®]

PARTS LIST **パーツリスト**

387RB-2

287RB-2

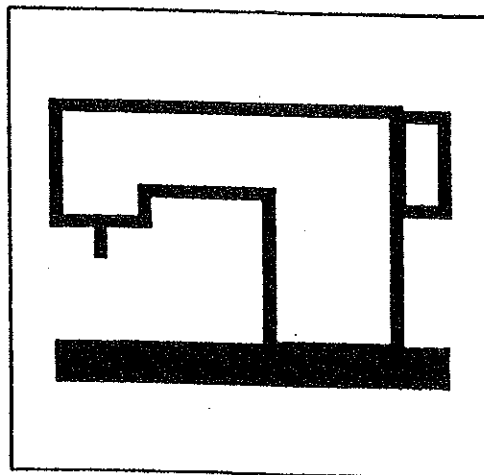

CONSOLIDATED SEWING MACHINE CORP.
U.S.A · JAPAN

INDEX

	pages
* 本体部分 ARM BED	1-4
* 面板、上板 FACE PLATE、ARM TOP COVER	5-6
* 調子板 TENSION	7-8
* 天ピン、上軸プーリー TAKE UP LEVER、ARM SHAFT、MACHINE PULLEY	9-10
* 下軸、下ベルトプーリー HOOK DRIVING SHAFT、SAFETY CLUTCH PULLEY	11-12
* 送り機構 FEEDING AND FEED LIFTING MECHANISM	13-14
* 縫目調節機構 STITCH LENGTH REGULATING MECHANISM	15-16
* 針棒土台、連結ロッド NEEDLE BAR ROCK FRAME、ROCK SHAFT CRANK CONNECTION	17-18
* 上下押え機構 PRESSER BAR、VIBRATING PRESSER BAR	19-20
* 大弓 KNEE LIFTER LIFTING LEVER	21-22
* 附属品 ACCESSORIES AND ATTACHMENTS	23-24

本体部分
ARM BED

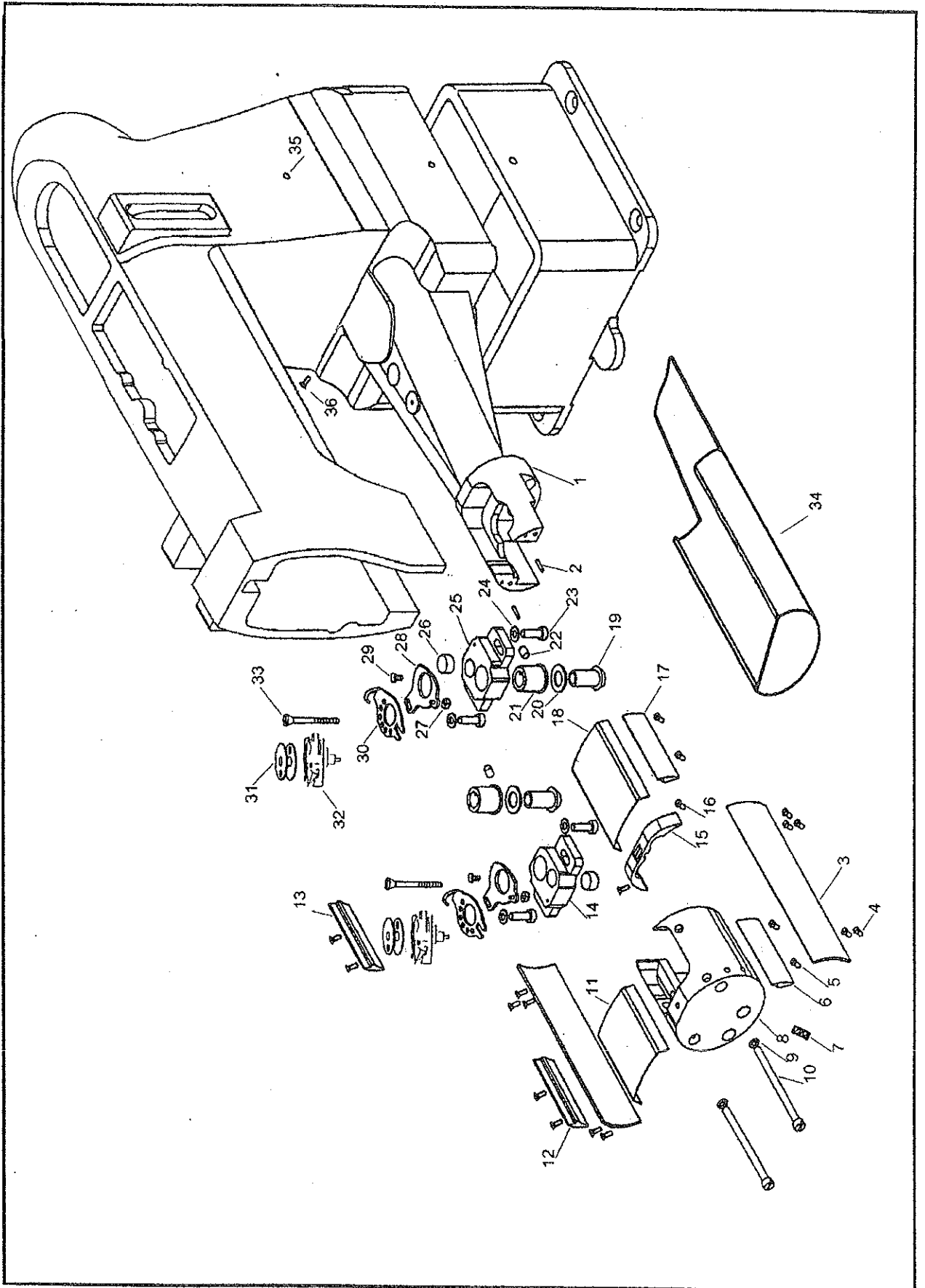

本体部分
ARM BED

NO	部品番号 PART NO	387RB-2	287RB-2	数量 QTY	品名	PARTS NAME
1		*		1	アーム	ARM BED
2	13073	*		2	ピン	PIN
3		*		2	連接板	CONNECTING PLATE
4		*		10	ねじ	SCREW 11/64X40
5	13023	*		8	ねじ	SCREW 3.4X36
6		*		1	案内板	FRONT GUIDE PLATE (RIGHT)
7		*		1	止めねじ	SET SCREW M4 L=4
8		*		1	連接土台	CONNECTING FRAME
9		*		2	ワッシャー	WASHER
10		*		2	ねじ	CONNECTING SCREW 13/64X32
11		*		1	スベリ板(前)	FRONT SLIDE PLATE
12		*		1	案内板	FRONT GUIDE PLATE (LEFT)
13		*		1	案内板	BACK GUIDE PLATE (LEFT)
14		*		1	カマ土台(左)	ROTATING HOOK BRACKET (LEFT)
15		*		1	針板	NEEDLE PLATE
16	13710	*		2	ねじ	SCREW 11/64X32
17		*		1	案内板	BACK GUIDE PLATE (RIGHT)
18		*		1	スベリ板(後)	BACK SLIDE PLATE
19	13734	*		2	小ギヤ	BEVEL GEAR FOR HOOK SHAFT
20	13735	*		2	ワッシャー	WASHER
21	13718	*		2	メタル	BUSHING
22	10581	*		2	止めねじ	SET SCREW 7/32X32 L=7
23	13717	*		2	ねじ	SCREW 13/64X32 L=16.5
24	13037	*		2	ワッシャー	WASHER
25	13716	*		1	カマ土台(右)	ROTATING HOOK BRACKET (RIGHT)
26	13081	*		2	フェルト	FELT
27	13714	*		2	角駒	SLIDE BLOCK
28	13712	*		2	ガイド板	GUIDE PLATE
29	10650	*		2	ねじ	SCREW 3.4X36 L=6
30	13711	*		2	オープナ	OPENER
31	15041	*		2	ボビン	BOBBIN
32	13719	*		2	カマ(組)	HOOK COMPLETE
33	12105	*		2	ねじ	CONNECTING SCREW 9/64X40
34		*		1	油槽	OIL RESERVIOR
35		*		1	パイプ	OIL PIPE
36	30046	*		1	ねじ	SCREW M4X0.7

本体部分
ARM BED

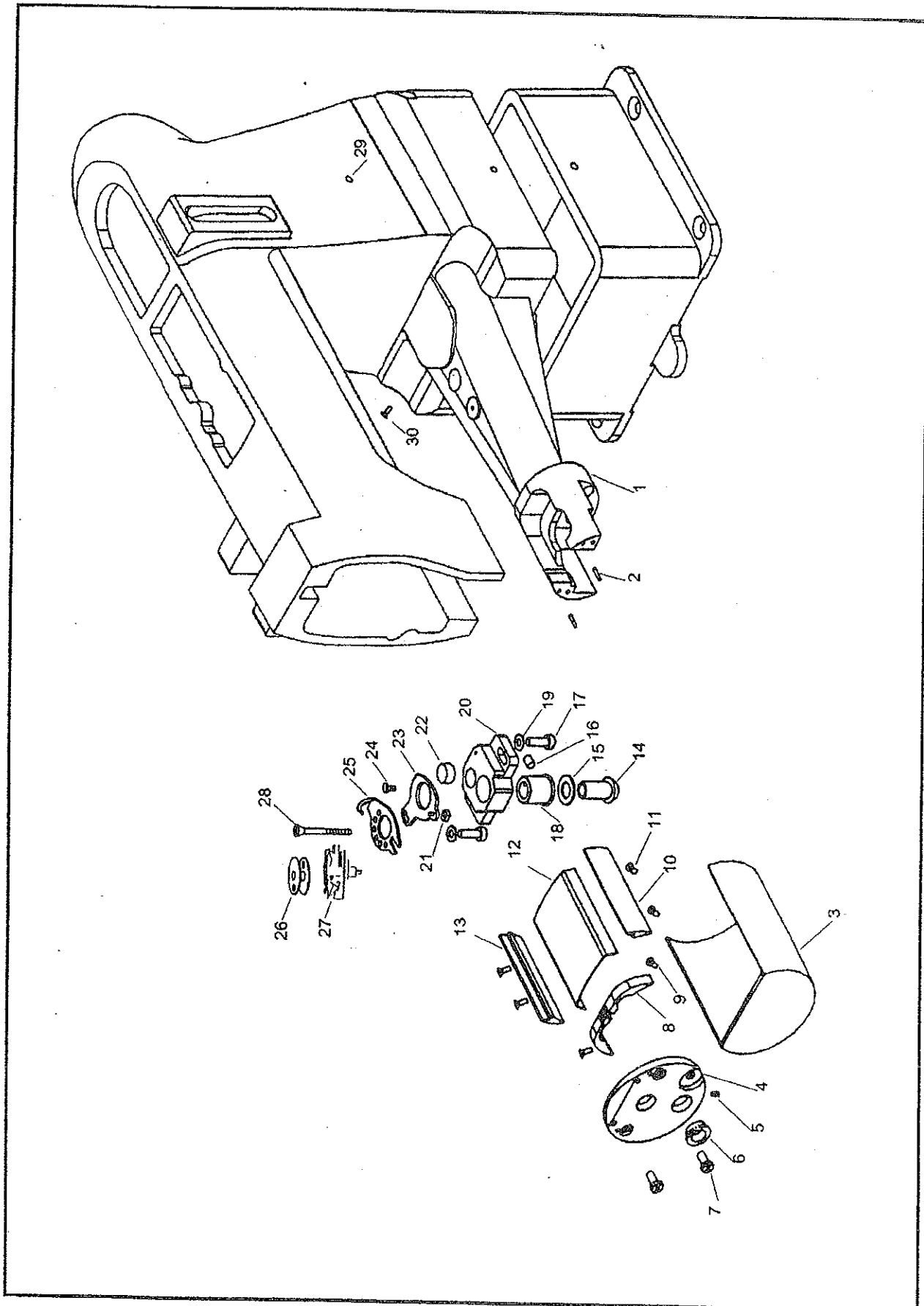

本体部分
ARM BED

NO	部品番号 PART NO	387RB-2	287RB-2	数量 QTY	品名	PARTS NAME
1			*	1	アーム	ARM BED
2	13073		*	2	ピン	PIN
3	13827		*	1	油槽	OIL RESERVIOR
4	13744		*	1	カバー	COVER
5	10630		*	1	止めねじ	SET SCREW 1/8X40 L=5
6	13738		*	1	メタル	BUSHING
7	13745		*	2	ねじ	SCREW 13/64X32 L=10.5
8	13709		*	1	針板	NEEDLE PLATE
9	13710		*	2	ねじ	SCREW 11/64X32
10	13671		*	1	案内板(右)	GUIDE PLATE (RIGHT)
11	13023		*	4	ねじ	SCREW 3.4X36
12	13660		*	1	スベリ板	SLIDE PLATE
13	13670		*	1	案内板(左)	GUIDE PLATE (LEFT)
14	13734		*	1	小ギヤ	BEVEL GEAR FOR HOOK SHAFT
15	13735		*	1	ワッシャー	WASHER
16	10581		*	1	止めねじ	SET SCREW 7/32X32 L=7
17	13717		*	2	ねじ	SCREW 13/64X32 L=16.5
18	13718		*	1	メタル	BUSHING
19	13037		*	2	ワッシャー	WASHER
20	13716		*	1	コマ土台	ROTATING HOOK BRACKET
21	13714		*	1	角駒	SLIDE BLOCK
22	13081		*	1	フェルト	FELT
23	13712		*	1	ガイド板	GUIDE PLATE
24	10650		*	1	ねじ	SCREW 3.4X36 L=6
25	13711		*	1	オープナ	OPENER
26	15041		*	1	ボビン	BOBBIN
27	13719		*	1	コマ(組)	HOOK COMPLETE
28	12105		*	1	ねじ	CONNECTING SCREW 9/64X40
29			*	1	パイプ	OIL PIPE
30	30046		*	1	ねじ	SCREW M4X0.7

面板、上板
FACE PLATE, ARM TOP COVER

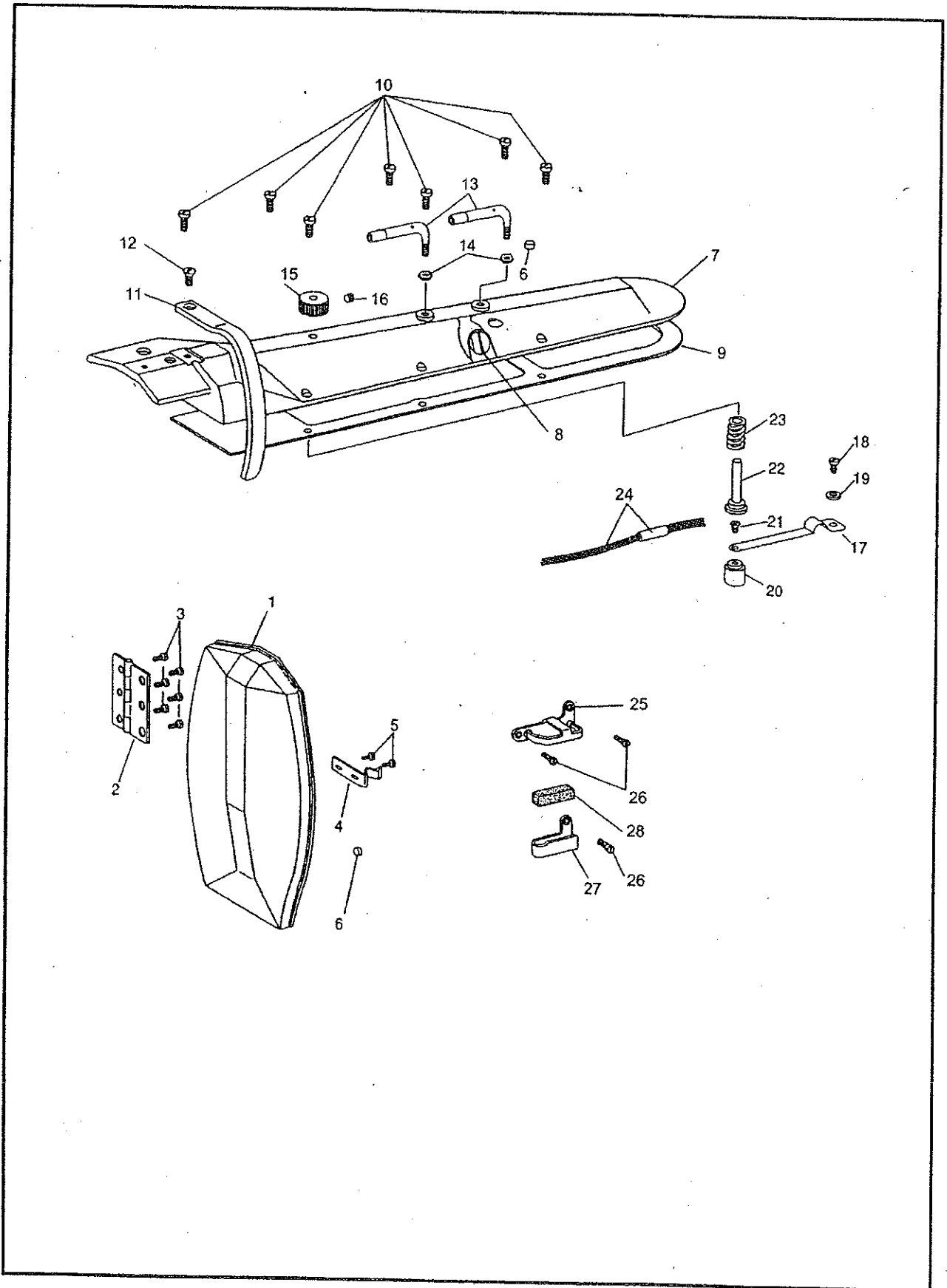

面板、上板
FACE PLATE、ARM TOP COVER

NO	部品番号 PART NO	387RB	287RB-1	数量 QTY	品名	PARTS NAME
1	15035	*	*	1	面板	FACE PLATE
2	15036	*	*	1	蝶番	HINGE
3	15039	*	*	6	止めねじ	SCREW 1/8X44 L=3.5
4	15037	*	*	1	面板ばね	FACE PLATE SPRING
5	15039	*	*	2	止めねじ	SCREW 1/8X44 L=3.5
6	15038	*	*	1	面板ゴム	RUBBER
6	15038	*	*	2	面板ゴム	RUBBER
7	13556	*	*	1	上板	ARM TOP COVER
8	11007	*	*	1	油量覗き窓	OIL LEVER INDICATOR
9	15004	*	*	1	上板ミートパッキン	GASKET
10	15007	*	*	7	止めねじ	SCREW 9/64x40 L=10.0
11	36708	*	*	1	天秤カバー	THREAD TAKE UP COVER
12	6031-02	*	*	1	止めねじ	SCREW 11/64x40 L=9.0
13	11006	*	*	2	上板系掛	ARM TOP COVER THREAD GUIDE
	11006	*	*	1	上板系掛	ARM TOP COVER THREAD GUIDE
14	13076-02	*	*	2	ナット	NUT 7/32X32
	13076-02	*	*	1	ナット	NUT 7/32X32
15	15057	*	*	1	給油遮断ダイヤル	OIL REGULATING DIAL
16	8009	*	*	1	止めねじ	SET SCREW 15/64X28 L=7.5
17	15086	*	*	1	油調節ばね	OIL CONTROL SPRING
18	8040	*	*	1	止めねじ	SCREW 9/64x40 L=8.0
19	11142	*	*	1	ワッシャー	WASHER
20	11004	*	*	1	油調節おもり	OIL REGULATOR
21	10597	*	*	1	止めねじ	SCREW 1/8x40 L=3.3
22	15058	*	*	1	給油遮断軸	OIL REGULATING STUD
23	15059	*	*	1	給油遮断スプリング	OIL REGULATING SPRING
24	15034C	*	*	1	ビニールチューブ、油芯(組)	OIL TUBE AND OIL WICK COMPLETE
25	15054	*	*	1	面系掛け(上)	THREAD GUIDE (UPPER)
26	10685	*	*	3	止めねじ	SCREW 3.4x36 L=6.5
27	10759-A	*	*	1	面系掛け(下)	THREAD GUIDE (LOWER)
28	10760	*	*	1	面系掛けフェルト	FELT

From the library of: Diamond Needle Corp

調子板
TENSION

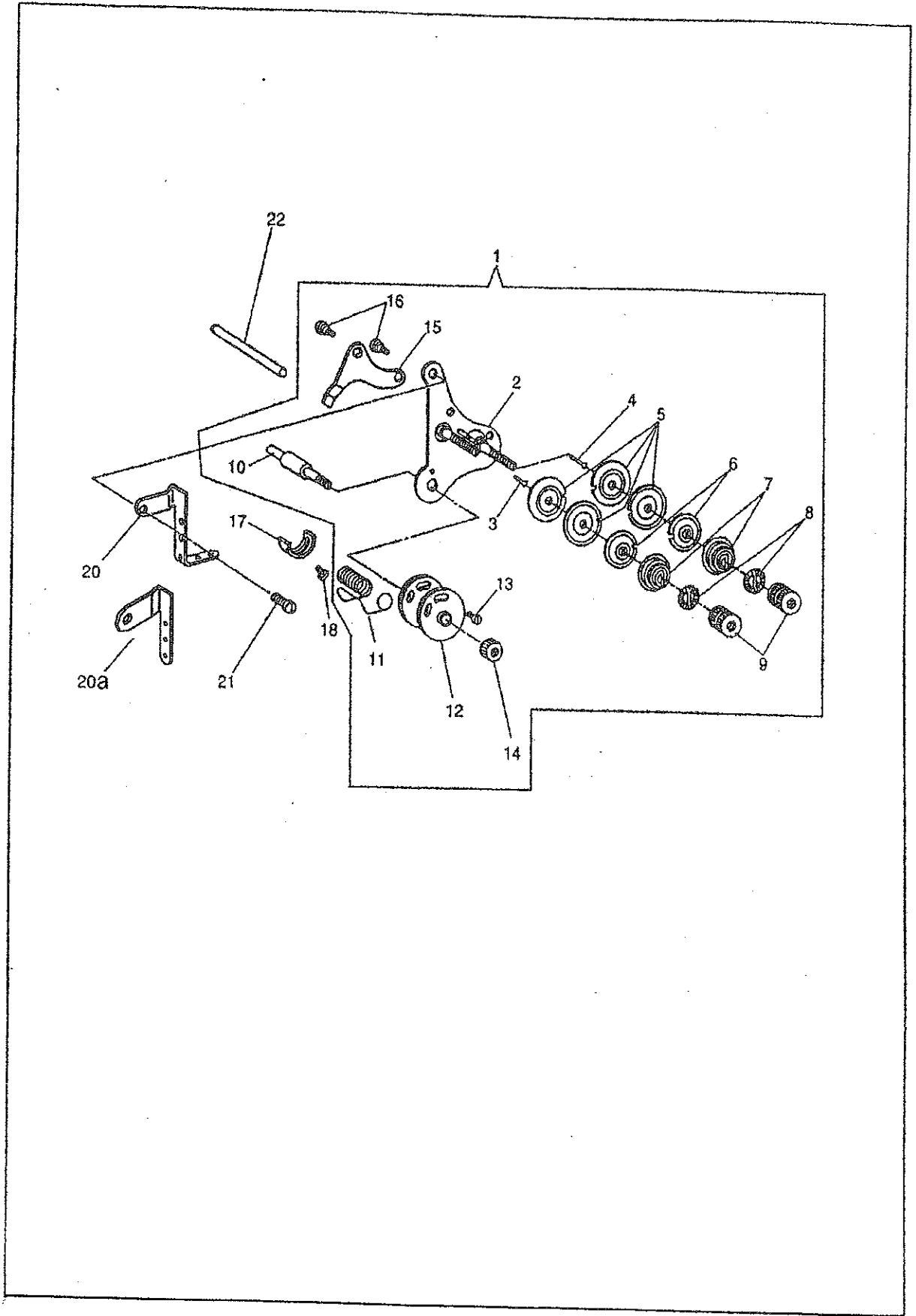

調子板
TENSION

NO	部品番号 PART NO	387RB	287RB-1	数量 QTY	品名	PARTS NAME
1	10961C-A	*		1	調子板組 (φ1.4)	TENSION BRACKET COMPLETE
2	10961	*		1	調子板	TENSION BRACKET
3	10957	*		1	糸ゆるめ段ピン	TENSION RELEASE PIN
4	10952	*		1	糸ゆるめ段ピン(長)	TENSION RELEASE PIN (LONG)
5	19531	*		4	調子皿	TENSION DISC
6	19532	*		2	丸一皿	TENSION RELEASE WASHER
7	19533	*		2	渦巻スプリング (φ1.4)	TENSION SPRING
8	28206	*		2	ローレットストッパ	NUT WASHER
9	19513	*		2	ローレットナット	NUT 1/4×40
10	10962	*		1	糸調子棒(長)	THREAD CONTROLLER STUD
11	10953	*		1	糸引スプリング	THREAD CONTROLLER SPRING
12	10694	*		2	二重皿	THREAD CONTROLLER DISC
13	B144682	*		1	二重皿止めねじ	SCREW 3/32×56 L=12.2
14	19534	*		1	ローレットナット	NUT
15	10678	*		1	糸ゆるめ板	TENSION RELEASE PLATE
16	19422	*		2	糸ゆるめ板段ねじ	SCREW
17	10690	*		1	スプリング受	THREAD CONTROLLER SPRING STOP
18	10650	*		1	スプリング受止めねじ	SCREW 3.4×36 L=6.0
20	15517	*		1	大糸掛	THREAD RETAINER
21	15055	*		1	大糸掛止めねじ	SCREW 11/64×32 L=9.0
22	10720	*		1	糸ゆるめピン(長)	TENSION RELEASE PLATE ROD
1		*		1	調子板組 (φ1.4)	TENSION BRACKET COMPLETE
2	10961	*		1	調子板	TENSION BRACKET
3		*				
4	10952	*		1	糸ゆるめ段ピン(長)	TENSION RELEASE PIN (LONG)
5	19531	*		2	調子皿	TENSION DISC
6	19532	*		1	丸一皿	TENSION RELEASE WASHER
7	19533	*		1	渦巻スプリング (φ1.4)	TENSION SPRING
8	28206	*		1	ローレットストッパ	NUT WASHER
9	19513	*		1	ローレットナット	NUT 1/4×40
10	10792	*		1	糸調子棒(長)	THREAD CONTROLLER STUD
11		*		1	糸引スプリング	THREAD CONTROLLER SPRING
12	10694	*		1	二重皿	THREAD CONTROLLER DISC
13	10695	*		1	二重皿止めねじ	SCREW 3/32×56 L=7.0
14	19534	*		1	ローレットナット	NUT
15	10678	*		1	糸ゆるめ板	TENSION RELEASE PLATE
16	19422	*		2	糸ゆるめ板段ねじ	SCREW
17	10690	*		1	スプリング受	THREAD CONTROLLER SPRING STOP
18	10650	*		1	スプリング受止めねじ	SCREW 3.4×36 L=6.0
20a	15062	*		1	大糸掛	THREAD RETAINER
21	15055	*		1	大糸掛止めねじ	SCREW 11/64×32 L=9.0
22	10720	*		1	糸ゆるめピン(長)	TENSION RELEASE PLATE ROD

天ピン、上軸、プーリー
 TAKE UP LEVER. ARM SHAFT. MACHINE PULLEY

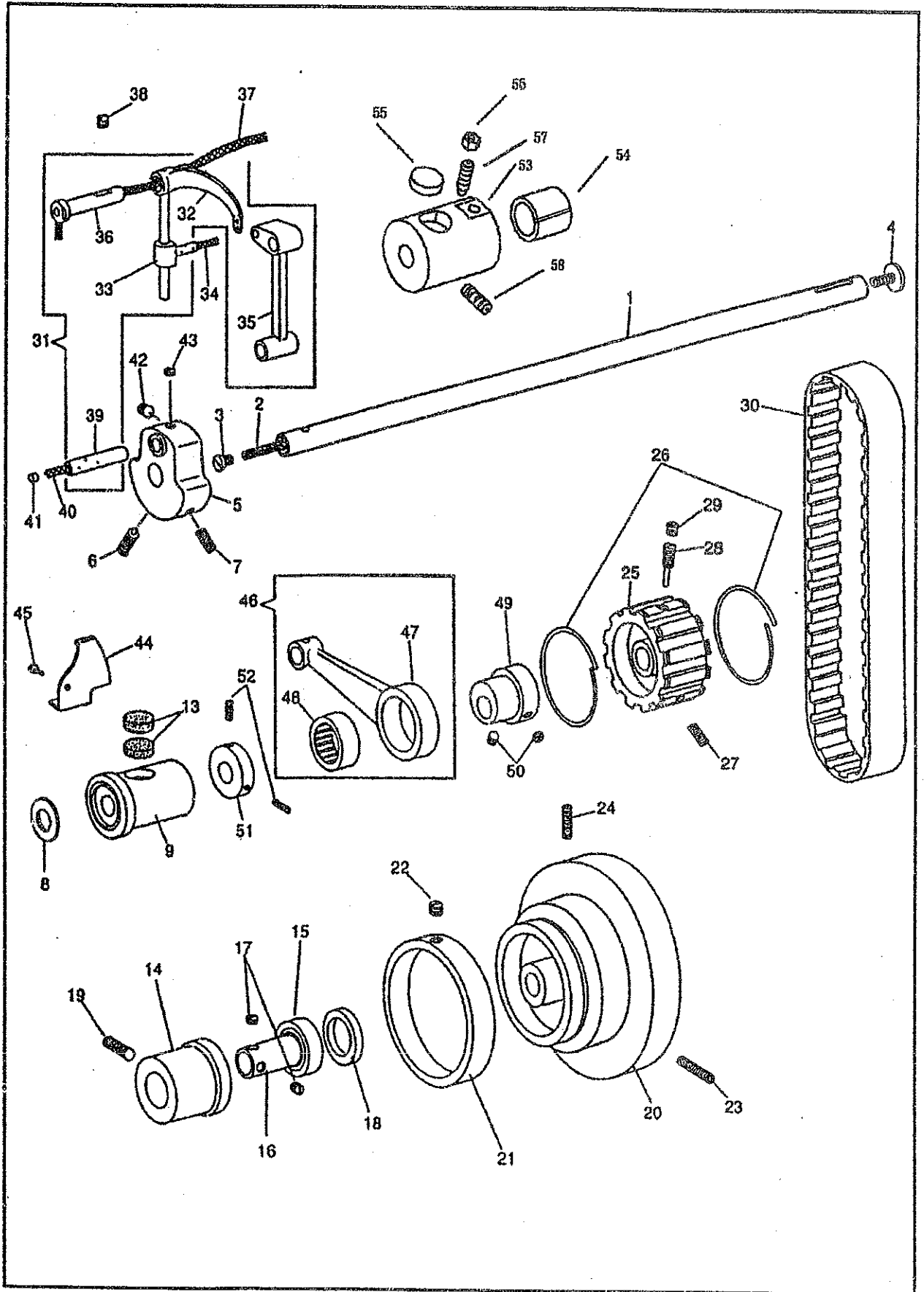

From the library of: Diamond Needle Corp

天ビン、上軸、プーリー

TAKE UP LEVER, ARM SHAFT, MACHINE PULLEY

NO	部品番号 PART NO	387RB	287RB-1	数量 QTY	品名	PARTS NAME
1	13557	*	*	1	上軸	ARM SHAFT
2	15033	*	*	1	上軸油芯	OIL WICK
3	10506	*	*	1	上軸油栓ねじ	OIL STOP SCREW 7.85X20 L=6.0
4	10577	*	*	1	プーリー押しねじ	PULLEY ADJUSTING SCREW 6.75X24 L=11.0
5	19414	*	*	1	クランクモーションカム	NEEDLE BAR CRANK
6	19415	*	*	1	位置決めねじ	POSITION SCREW 1/4X28 L=20.0
7	19416	*	*	1	止めねじ	SET SCREW 1/4X28 L=14.0
8	10563	*	*	1	上軸メタル(左)ワッシャー	WASHER
9	10562	*	*	1	上軸メタル(左)	ARM SHAFT BUSHING (LEFT)
13	10725	*	*	2	上軸メタル(左)フェルト	OIL FELT
14	13074	*	*	1	上軸ベアリングケース	ARM SHAFT BALL BEARING ADAPTOR
15	10567	*	*	1	上軸ベアリング	ARM SHAFT BALL BEARING
16	13361	*	*	1	上軸ベアリングカラー	ARM SHAFT BALL BEARING ADAPTOR SLEEVE
17	19418	*	*	2	止めねじ	SET SCREW 1/4X28 L=4.5
18	10568	*	*	1	溝なしリング	BALL BEARING RETAINING RING
19	10571	*	*	1	上軸ベアリングケース止めねじ	SCREW 6.75X24 L=20.0
20	10504	*	*	1	プーリー	MACHINE PULLEY
21		*	*	1	文字リング	FEED INDICATING (W/O BELT GUARD)
22	10566	*	*	1	文字リングねじ	SET SCREW 1/4X32 L=5.5
23	10576	*	*	1	位置決めねじ	POSITION SCREW 15/64X28 L=21.0
24	10579	*	*	1	止めねじ	SET SCREW 15/64 X28 L=20.0
25	10569	*	*	1	ベルトプーリー	ARM SHAFT CONNECTING BELT PULLEY
26	10574	*	*	2	ベルトプーリーリング	BELT PULLEY SPRING FLANGE
27	10571-G	*	*	1	ベルトプーリー止めねじ	SET SCREW 6.75X24 L=20.0
28	10570	*	*	1	ベルトプーリーピンねじ	POSITION SCREW 6.75X24 L=14.5
29	10524-G	*	*	1	ベルトプーリーピンねじ止めねじ	POSITION SCREW SET SCREW 6.75X24 L=6.5
30	13749	*	*	1	タイミングベルト	ARM SHAFT CONNECTING BELT
32	18003	*	*	1	天秤	THREAD TAKE UP LEVER
32	15504	*	*	1	天秤	THREAD TAKE UP LEVER
33	15026	*	*	1	天秤抱き	THREAD TAKE UP LEVER DRIVING STUD
33		*	*	1	天秤抱き	THREAD TAKE UP LEVER DRIVING STUD
34	10728	*	*	1	天秤抱き油芯	OIL WICK
35	10528	*	*	1	針棒クランク	NEEDLE BAR CONNECTING LINK
36	15013	*	*	1	天秤ピン	THREAD TAKE UP LEVER HINGE STUD
37	11042	*	*	1	天秤ピン油芯	OIL WICK
38	10524	*	*	1	天秤ピン止めねじ	SET SCREW 6.75X24 L=6.5
39	10523	*	*	1	針棒クランクピン	NEEDLE BAR CONNECTING LINK STUD
40	10728	*	*	1	針棒クランクピン油芯	OIL WICK
41	15038	*	*	1	油ゴム栓	RUBBER OIL STOPPER
42	19417	*	*	1	針棒クランクピン止めねじ(長)	SCREW 1/4X28 L=6.5
43	19418	*	*	1	針棒クランクピン止めねじ(短)	SCREW 1/4X28 L=4.5
44	10551	*	*	1	天秤油受け	THREAD TAKE UP LEVER OIL GUARD
45	10650	*	*	1	天秤油受け止めねじ	SCREW 3.4X36 L=6.0
46	10772G	*	*	1	上連結ロッド	LIFTING ECCENTRIC CONNECTING COMPLETE
47	10772	*	*	1	上連結ロッド	LIFTING ECCENTRIC CONNECTION
48	10773	*	*	1	ニードルベアリング	NEEDLE BEARING
49	19427	*	*	1	中押え上下カム	LIFTING ECCENTRIC
50	19508	*	*	2	中押え上下カム止めねじ	SET SCREW 1/4X40 L=5.5
51	11879	*	*	1	中押え上下カムカラー	LIFTING ECCENTRIC COLLAR
52	10573	*	*	2	中押え上下カムカラー止めねじ	SET SCREW 7/32X32 L=11.0
53	13406	*	*	1	上軸メタル(中)	ARM SHAFT BUSHING (MIDDLE)
54	13407	*	*	1	上軸メタル(内)	BUSHING (INSIDE)
55	10725	*	*	1	フェルト	OIL FELT
56	16708	*	*	1	ナット	NUT 1/4X28
57	19415	*	*	1	位置決めねじ	POSITION SCREW 1/4X28 L=20
58	10571	*	*	1	止めねじ	SET SCREW 17/64X24 L=20

下軸、下ベルトプーリー
HOOK DRIVING SHAFT, SAFETY CLUTCH PULLEY

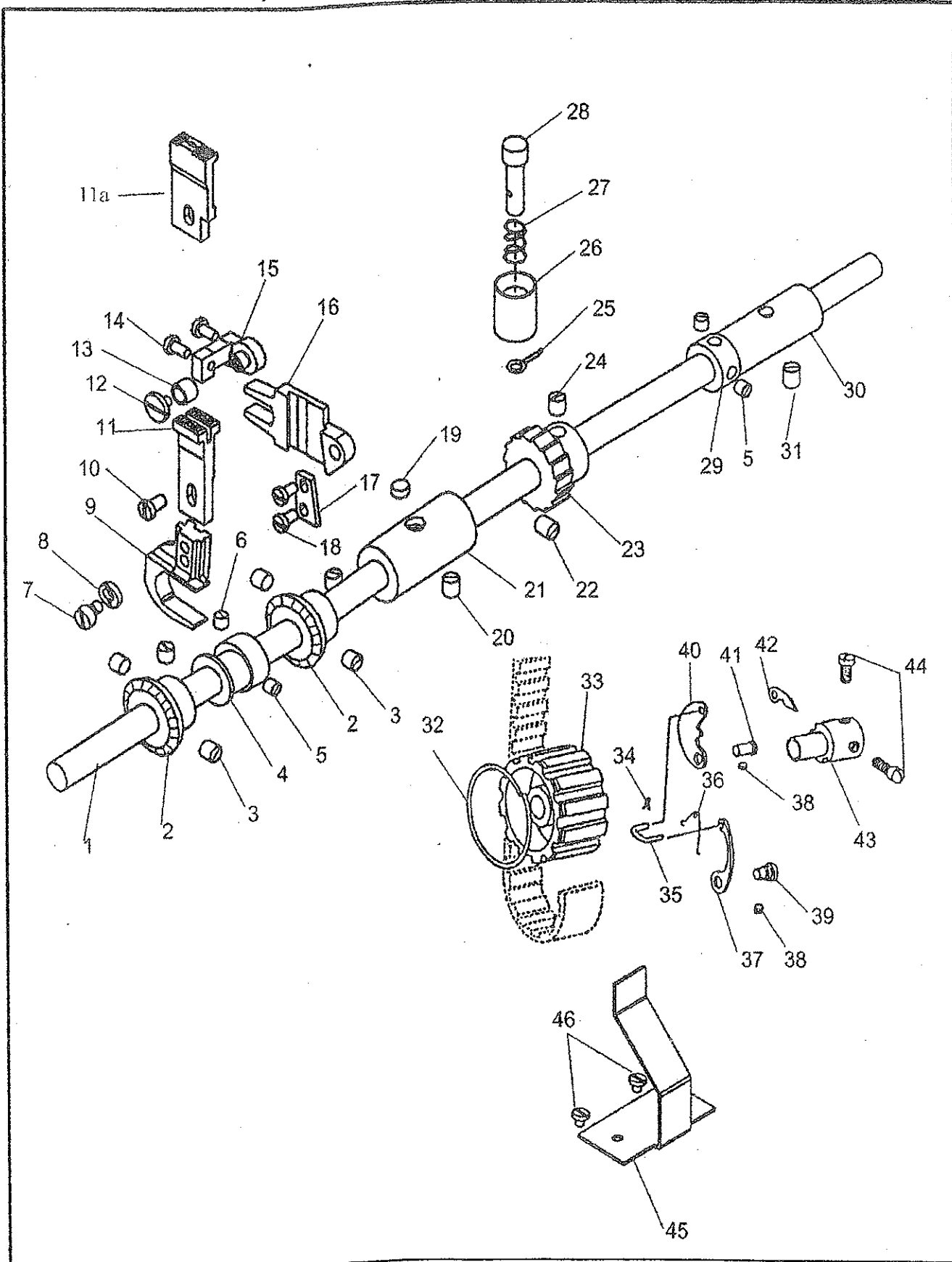

下軸、下ベルトプーリー

HOOK DRIVING SHAFT, SAFETY CLUTCH PULLEY

NO	部品番号 PART NO	387RB	287RB-1	数量 QTY	品名	PARTS NAME
1	NE-1	*		1	下軸	HOOK DRIVING SHAFT
1	13043		*	1	下軸	HOOK DRIVING SHAFT
2	13733	*		2	大ギヤ	HOOK DRIVING GEAR
2	13733		*	1	大ギヤ	HOOK DRIVING GEAR
3	19508	*		6	止めねじ	SET SCREW 1/4X40 L=5.5
3	19508		*	3	止めねじ	SET SCREW 1/4X40 L=6.5
4	13725	*	*	1	送り偏心	FEED ECCENTRIC
5	13085	*	*	3	ねじ	SCREW 13/64X32 L=4.3
6	13031	*	*	1	ねじ	SCREW 13/64X32 L=4.7
7	100724	*	*	1	ねじ	SCREW 11/64X40 L=6
8	13751	*	*	1	ワッシャ	ADJUSTMENT WASHER
9	13722	*	*	1	上下送り腕	FOODE LIFTING ROCK SHAFT CRANK
10	10561	*	*	1	止めねじ	SET SCREW 11/64X32 L=6.5
11		*		1	送り歯	FEED DOG
11a	13708		*	1	送り歯	FEED DOG
12	13743	*	*	1	ねじ	SCREW 9/64X40 L=5
13	13742	*	*	1	ローラー	ROLLER
14	13740	*	*	2	ねじ	SCREW 9/64X40 L=7
15	13739	*	*	1	支工	RETAINING FRAME
16	13721	*	*	1	水平送り腕	FEED ROCK SHAFT CRANK
17	13723	*	*	1	案内板	WEDGE-SHAPED BLOCK
18	10650	*	*	2	ねじ	SCREW 3.4X36 L=6
19		*	*	1	フェルト	FELT
20	10524	*	*	1	ねじ	SCREW 17/64X24 L=6.5
21	13746	*	*	1	下軸メタル(左)	HOOK DRIVING SHAFT BUSHING (LEFT)
22	19417	*	*	1	ねじ	SCREW 1/4X28 L=6.5
23	13044	*	*	1	爪車	HOOK DRIVING SHAFT LOCK RATCHET
24		*	*	1	ねじ	SCREW 1/4X28 L=6
25	13048	*	*	1	ピン	SAFE CLUTCH SHAFT PIN
26	13748	*	*	1	メタル	SAFE CLUTCH BUSHING
27	13047	*	*	1	バネ	SAFE CLUTCH SPRING
28	13747	*	*	1	軸	SAFE CLUTCH SHAFT
29	20254	*	*	1	カラー	COLLAR
30	13029	*	*	1	下軸メタル(右)	HOOK DRIVING SHAFT BUSHING (RIGHT)
31	10766	*	*	1	ねじ	SCREW 1/4X32 L=7
32	10574	*	*	1	プーリーリング	PULLEY SPRING FLANGE
33	10610	*	*	1	下ベルトプーリー	SAFETY CLUTCH PULLEY
34	10620	*	*	1	下ベルトプーリー割ピン	SAFETY CLUTCH THROW IN LATCH PIN
35	10618	*	*	1	下ベルトプーリー小連結	SAFETY CLUTCH RATCHET CONNECTING LINK
36	10619	*	*	1	下ベルトプーリーピン	SAFETY CLUTCH THROW IN LATCH SPRING
37	10615	*	*	1	下ベルトプーリー板バネ	SAFETY CLUTCH LOCKING LEVER SPRING
38	10581	*	*	2	ねじ	SCREW 7/32X32 L=7
39	10614	*	*	1	下ベルトプーリー段ピン	HINGE PIN
40	10616	*	*	1	下ベルトプーリー掛金	SAFETY CLUTCH LOCKING LEVER
41	10613	*	*	1	下ベルトプーリー掛金ピン	HINGE STUD
42	10617	*	*	1	下ベルトプーリー小爪	SAFETY CLUTCH RATCHET
43	10611	*	*	1	下ベルトプーリー心棒	SAFETY CLUTCH COLLAR
44	10612	*	*	2	止めねじ	SCREW 1/4X32 L=10.5
45		*	*	1	位置決め板	INDICATING PLATE
46	10597	*	*	2	ねじ	SCREW 1/8X40 L=3.3

送り機構

FEEDING AND FEED LIFTING MECHANISM

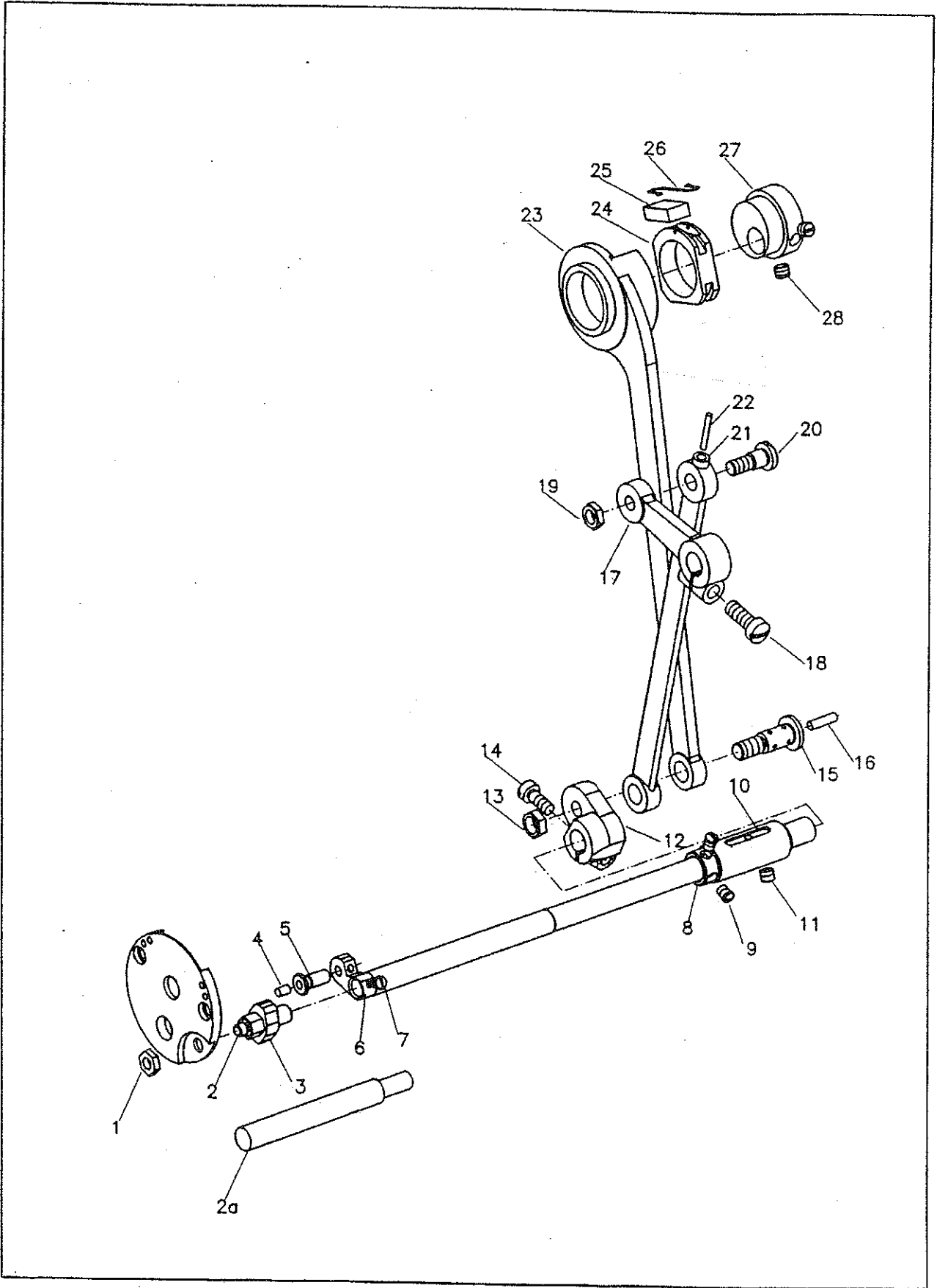

送り機構

FEEDING AND FEED LIFTING MECHANISM

NO	部品番号 PART NO	387RB	287RB-1	数量 QTY	品名	PARTS NAME
1	13076		*	1	ナット	NUT
2	13012		*	1	ピン	PIN
2a		*		1	ピン	PIN
3		*	*	1	フェルト	FELT
4		*	*	1	油芯	OIL WICK
5	13724	*	*	1	ピン	PIN
6	13736	*	*	1	送り軸	FEED ROCK SHAFT
7	10532	*	*	1	止めねじ	SET SCREW 5/32X40 L=9
8	20254	*	*	1	カラー	COLLAR FOR HOOK SHAFT
9	13033	*	*	1	止めねじ	SET SCREW 13/64X32 L=5
10	13029	*	*	1	メタル	FEED ROCK SHAFT BUSHING
11	10766	*	*	1	止めねじ	SET SCREW 1/4X32 L=7
12	13053	*	*	1	送り腕	FEED LINK CRANK
13	11185	*	*	1	ナット	NUT
14	13078	*	*	1	止めねじ	SET SCREW 7/32X32 L=13
15	13072	*	*	1	ピン	PIN
16		*	*	1	油芯	OIL WICK
17	13732	*	*	1	腕	NEEDLE BAR VIBRATING CRANK
18	10519	*	*	1	止めねじ	SET SCREW
19	10636	*	*	1	ナット	NUT
20	13134	*	*	1	ピン	PIN
21	13731	*	*	1	連接幹	CONNECTING LINK
22	10728	*	*	1	油芯	OIL WICK
23	13728	*	*	1	リンク	LINK
24	13729	*	*	1	角駒	FEEDING SLIDE BLOCK
25	10722	*	*	1	フェルト	FELT
26	10723	*	*	1	ホルダ	HOLDER
27	13408	*	*	1	偏心	ECCENTRIC WHEEL
28	10566	*	*	2	止めねじ	SET SCREW 1/4X32 L=5.5

縫目調節機構
STITCH LENGTH REGULATING MECHANISM

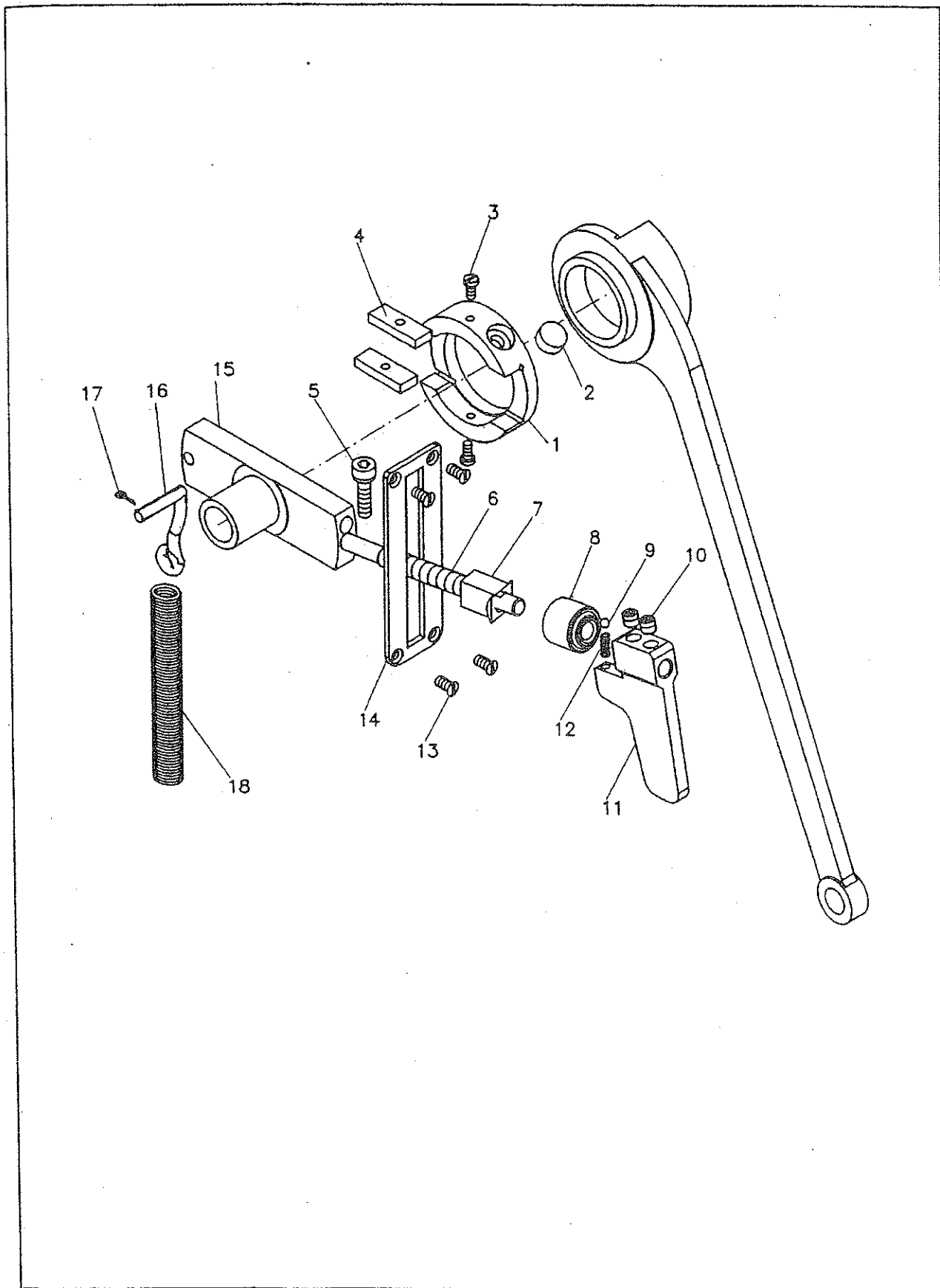

From the library of: Diamond Needle Corp

縫目調節機構

STITCH LENGTH REGULATING MECHANISM

NO	部品番号 PART NO	387RB	287RB-1	数量 QTY	品名	PARTS NAME
1	13411	*	*	1	カラー	COLLAR
2	11069	*	*	1	フェルト	FELT
3	8044	*	*	2	止めねじ	SET SCREW 1/8X44 L=6
4	13412	*	*	2	フェルト	FELT
5	4041	*	*	1	ねじ	SCREW M5 L=16
6	17061	*	*	1	送り調節ネジ	FEED REGULATOR SCREW BAR
7	13417	*	*	1	メタル	GUIDE BUSHING
8	13416	*	*	1	ナット	NUT
9	8158	*	*	1	ボール	STEEL BALL
10	18028	*	*	2	止めねじ	SET SCREW
11	18027	*	*	1	バックレバー	FEED REVERSING LEVER
12	8157	*	*	1	バネ	SPRING
13	7041	*	*	4	ねじ	SCREW
14	13730	*	*	1	ダイヤル	DIAL
15	13413	*	*	1	スライド板	SLIDE BLOCK
16	13419	*	*	1	連接幹	CONNECTING LINK
17	15076	*	*	1	ピン	PIN
18	10806	*	*	1	バネ	SPRING

針棒土台、連結ロッド
NEEDLE BAR ROCK FRAME, ROCK SHAFT CRANK CONNECTION

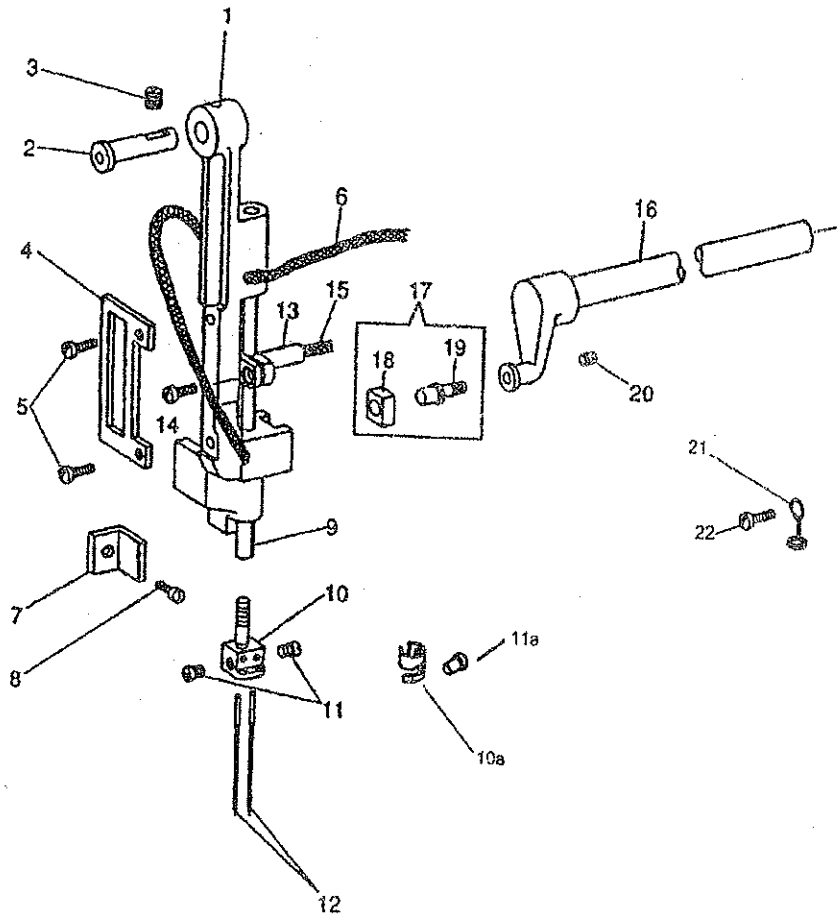

From the library of: Diamond Needle Corp

針棒土台、連結ロッド

NEEDLE BAR ROCK FRAME, ROCK SHAFT CRANK CONNECTION

NO	部品番号 PART NO	387RB	287RB-1	数量 QTY	品名	PARTS NAME
1	15547-A	*		1	針棒土台	NEEDLE BAR ROCK FRAME
1	15110-A		*	1	針棒土台	NEEDLE BAR ROCK FRAME
2	11875	*	*	1	針棒土台ピン	HINGE STUD
3	10525	*	*	1	止めねじ	SET SCREW 6.75X24 L=9.0
4	15117	*	*	1	振れ止板	SLIDE BLOCK PLATE
5	8100	*	*	2	振れ止板止めねじ	SCREW 9/64X40 L=8.5
6	15031	*	*	1	針棒土台油芯	OIL WICK
7	10560	*	*	1	イケール	NEEDLE BAR ROCK FRAME POSITION BRACKET
8	10561	*	*	1	止めねじ	LIFTING BRACKET GUIDE SCREW 11/64X32 L=6.5
9	10955	*		1	針棒	NEEDLE BAR
9	15032		*	1	針棒	NEEDLE BAR
10	10005	*		1	針棒1/4"	NEEDLE CLAMP 1/4" (STANDARD)
10a	15089		*	1	系案内	THREAD GUIDE
11	10535	*		2	ねじ	NEEDLE SET SCREW 3.4X36 L=4.5
11a			*	1	針止めねじ	SCREW 1/8X40 L=4.3
12	N0122	*		2	針	NEEDLE
12	N0122		*	1	針	NEEDLE
13	10904	*		1	針棒抱き	NEEDLE BAR CONNECTING STUD
13	10531		*	1	針棒抱き	NEEDLE BAR CONNECTING STUD
14	10532	*		1	針棒抱き締ねじ	PINCH SCREW 5/32X40 L=9.0
14	13365		*	1	針棒抱き締ねじ	PINCH SCREW M4X0.7 L=9.0
15	10726	*	*	1	針棒抱き油芯	OIL WICK
16	10578	*	*	1	上送り竿	NEEDLE BAR ROCK FRAME ROCK SHAFT
17	11876C	*	*	1	上送り竿角玉(組)	SLIDE BLOCK COMPLETE
18	11877	*	*	1	上送り竿角玉	SLIDE BLOCK
19	11876	*	*	1	上送り竿ピンねじ	SLIDE BLOCK STUD
20	10581	*	*	1	上送り竿ピンねじ止めねじ	SET SCREW 7/32X32 L=7.0
21	4221	*	*	1	油芯押え	OIL WICK RETAINER
22	15007	*	*	1	糸調子棒(短)止めねじ	SCREW 9/64X40 L=10.0

上下押え機構
 PRESSER BAR, VIBRATING PRESSER BAR

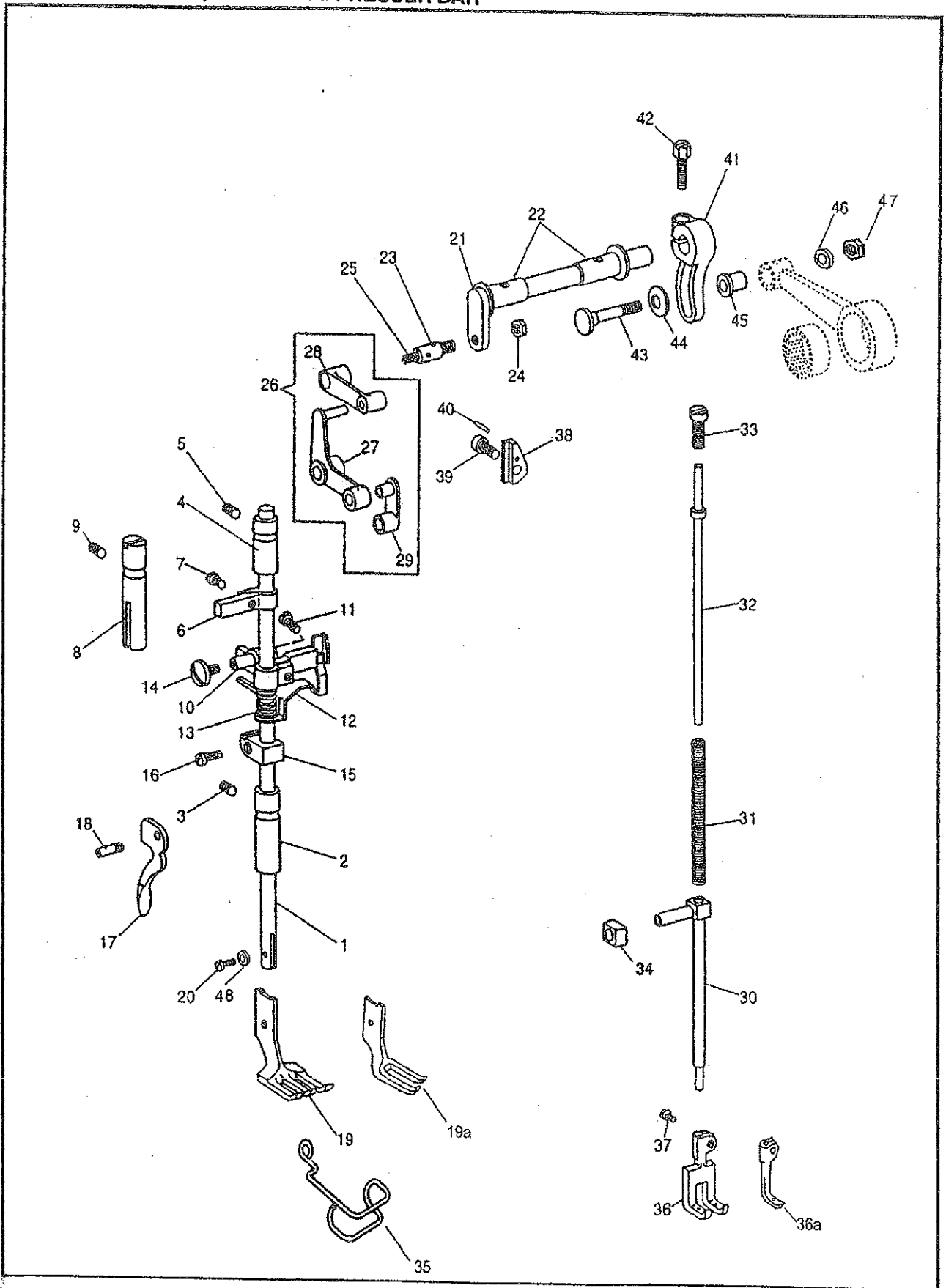

上下押え機構

PRESSER BAR、VIBRATING PRESSER BAR

NO	部品番号 PART NO	387RB	287RB-1	数量 QTY	品名	PARTS NAME
1	10540	*	*	1	押え棒	PRESSER BAR
2	10539-A	*	*	1	押え棒(下)メタル	PRESSER BAR BUSHING (LOWER)
3	10761	*	*	1	止めねじ	SET SCREW 6.75×24 L=11.0
4	10538	*	*	1	押え棒(上)メタル	PRESSER BAR BUSHING (UPPER)
5	10761	*	*	1	止めねじ	SET SCREW 6.75×24 L=11.0
6	10541	*	*	1	押え棒案内	PRESSER BAR POSITION GUIDE BRACKET
7	10662	*	*	1	止めねじ	SCREW 5/32×40 L=6.5
8	10543	*	*	1	案内棒	PRESSER BAR POSITION GUIDE
9	10761	*	*	1	止めねじ	SET SCREW 6.75×24 L=11.0
10	18479	*	*	1	押え棒抱き	PRESSER BAR LIFTING BRACKET
11	19518	*	*	1	押え棒抱き締ねじ	SCREW 11/64×40 L=14.0
12	10546-A	*	*	1	押え棒抱き下板	TENSION RELEASE SLIDE
13	10547	*	*	1	押え棒抱き下板ばね	TENSION RELEASE SPRING
14	18480	*	*	1	くの字止めねじ	LIFTING BELL CRANK SCREW 11/64×40 L=8.0
15	13360	*	*	1	押え棒抱きリング	PRESSER BAR SPRING BARCKET
16	13365	*	*	1	押え棒抱きリング締ねじ	PINCH SCREW M4X0.7 L=9.0
17	10659	*	*	1	押え上げレバー	PRESSER BAR LIFTER
18	10660	*	*	1	押え上げレバーピンねじ	HINGE SCREW 4.5×32
19	10185	*	*	1	外押え(1/4")	LIFTING PRESSER FOOT (1/4")
19a	10796	*	*	1	外押え	LIFTING PRESSER FOOT
20	10749	*	*	1	外押え止めねじ	SCREW 3.4×36 L=9.0
21	19425	*	*	1	横軸	LIFTING ROCK SHAFT
22	10514	*	*	2	横軸メタル	LIFTING ROCK SHAFT BASHING
23	16709	*	*	1	横軸ピンねじ	SCREW 1/4×28
24	19518	*	*	1	横軸ピンねじナツ	NUT 1/4×28
25	10728	*	*	1	横軸ピンねじ油芯	OIL WICK
26	10558C	*	*	1	くの字セット	LIFTING BELL CRANK COMPLETE
27	10558	*	*	1	くの字	LIFTING BELL CRANK
28	10557	*	*	1	くの字連結(大)	LIFTING BELL CRANK LINK
29	10556	*	*	1	くの字連結(小)	VIBRATING PRESSER BAR CONNECTING LINK
30	17101-A	*	*	1	中押え棒	VIBRATING PRESSER BAR
31	10554	*	*	1	中押えスプリング	VIBRATING PRESSER BAR EXTENSION SPRING
32	10553-A	*	*	1	中押えスプリング棒	VIBRATING PRESSER BAR EXTENSION
33	15080	*	*	1	中押え棒押しねじ	SCREW 5/16×24 L=16.0
34	15118	*	*	1	振れ止角玉	VIBRATING PRESSER BAR SLIDE BLOCK
35	10937-01	*	*	1	フィンガーガード	FINGER GUARD
35		*	*	1	フィンガーガード	FINGER GUARD
36	10285	*	*	1	中押え(1/4")	VIBRATING PRESSER FOOT (1/4")
36a	10795	*	*	1	中押え	VIBRATING PRESSER FOOT
37	10662	*	*	1	中押え止めねじ	SCREW 5/32×40 L=6.5
37		*	*	1	中押え止めねじ	SCREW 11/64×40 L=7.0
38	10548-A	*	*	1	押え棒抱き振れ止め板	LIFTING BRACKET GUIDE BLOCK
39	10519	*	*	1	止めねじ	PINCH SCREW 6.75X24 L=17.5
40	15111	*	*	1	ピン	PIN
41	19419	*	*	1	上下カム連結だるま	LIFTING ECCENTRIC CONNECTING CRANK
42	19420	*	*	1	上下カム連結だるま締ねじ	PINCH SCREW 1/4×28 L=16.0
43	10775	*	*	1	上連結ロッド段ねじ	HINGE SCREW 7/32×32
44	10703	*	*	1	上連結ロッド段ねじワッシャー	WASHER
45	10774	*	*	1	上連結ロッドパイプ	LIFTING ECCENTRIC CONNECTION COLLAR
46		*	*	1	ワッシャー	WASHER
47		*	*	1	ナツト	NUT 7/32×32
48	10677	*	*	1	ワッシャー	WASHER

大弓
KNEE LIFTER LIFTING LEVER

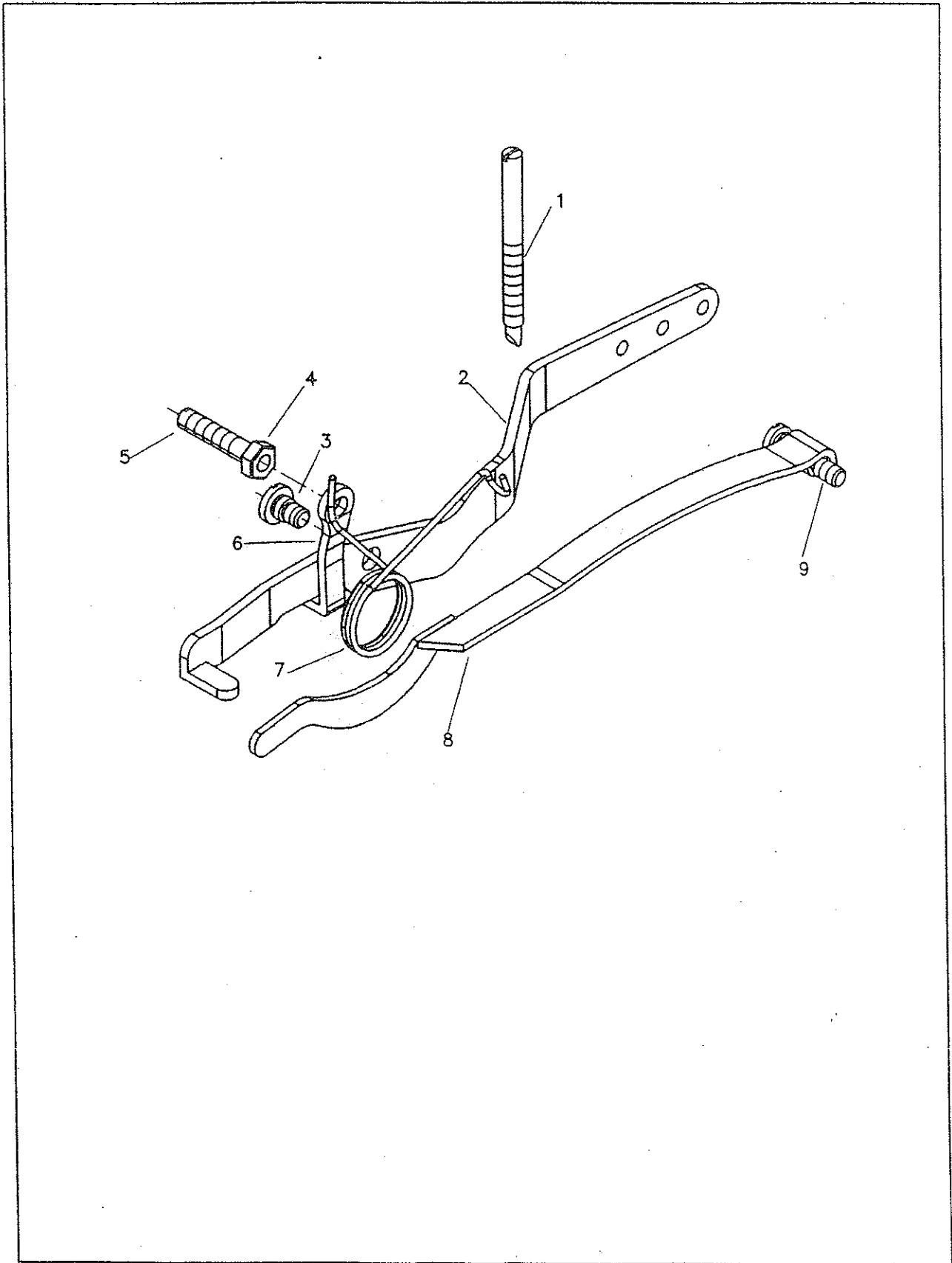

大弓

KNEE LIFTER LIFTING LEVER

NO	部品番号 PART NO	387RB	287RB-1	数量 QTY	品名	PARTS NAME
1	11156	*	*	1	大板ばね調節ねじ	PRESSER BAR SPRING REGULATING SCREW
2	13058-A	*	*	1	大弓	KNEE LIFTER LIFTING LEVER
3	10712	*	*	1	ねじ	SCREW 6.75X24
4		*	*	1	ナット	NUT 17/64X24
5		*	*	1	ねじ	SCREW 17/64X24 L=32
6		*	*	1	小弓	KNEE LIFTER CONNECTING LEVER
7	13059	*	*	1	弓ばね	SPRING
8	10705	*	*	1	押し棒大板ばね	PRESSER BAR SPRING (FLAT)
9	10706	*	*	1	大板ばね受けねじ	PRESSER BAR SPRING SUPPORT SCREW

附属品
ACCESSORIES AND ATTACHMENTS

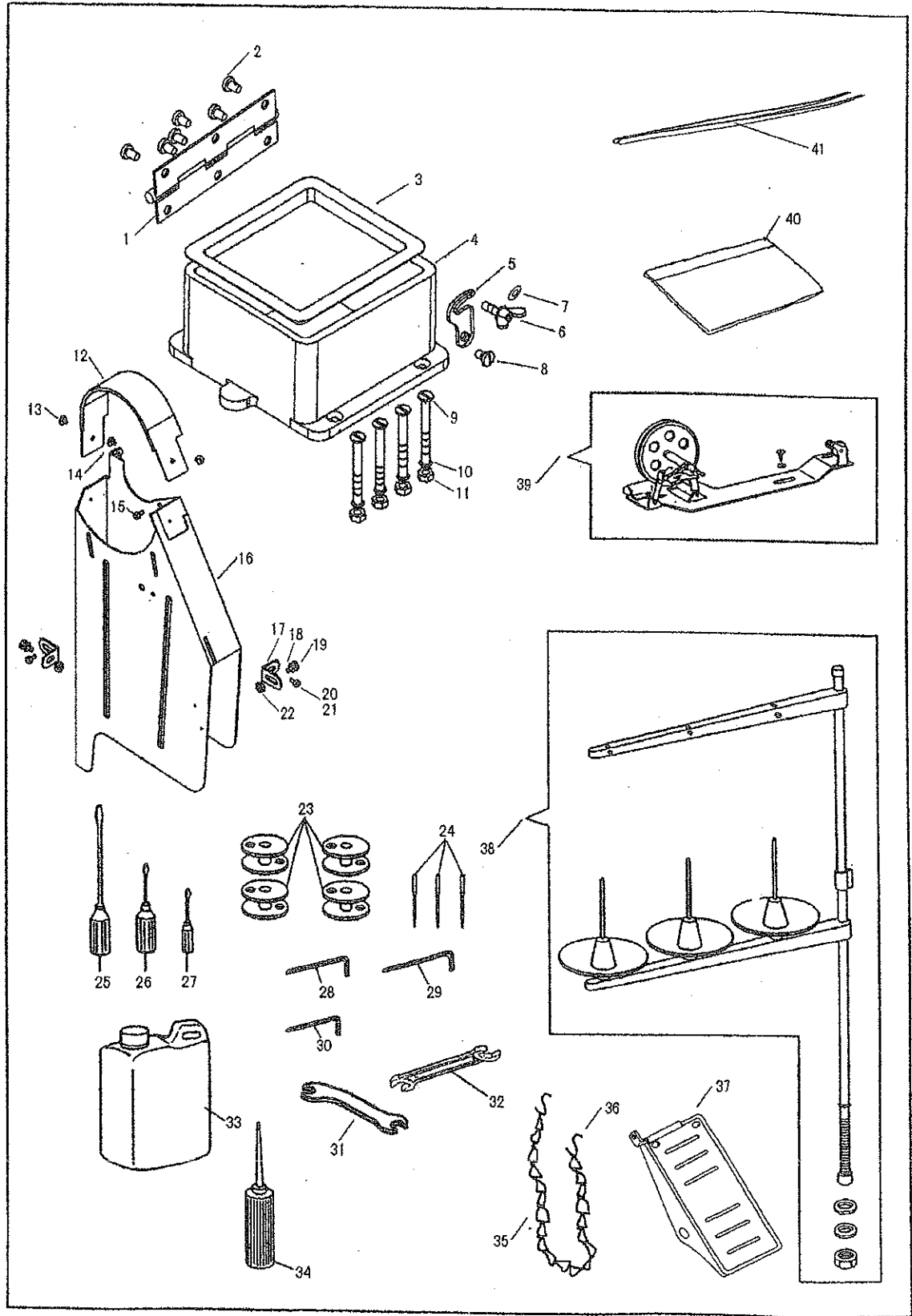

附属品
ACCESSORIES AND ATTACHMENTS

NO	部品番号 PART NO	387RB-2	287RB-2	数量 QTY	品名	PARTS NAME
1	13004	*	*	1	蝶番	HINGE
2	13005	*	*	6	ねじ	SCREW 15/64X26 L=9.7
3		*	*	1	油槽	OIL RESERVIOR
4	13003	*	*	1	支工	SUPPORTER
5	13006	*	*	1	連接板	LINK PLATE
6	13007	*	*	1	止めねじ	SET SCREW M6
7	13008	*	*	1	ワッシャー	WASHER
8	10712	*	*	1	ねじ	SCREW 1/4X28
9	13096	*	*	4	ねじ	CONNECTING FRAME
10		*	*	4	ワッシャー	WASHER
11		*	*	4	ナット	NUT
12	13426	*	*	1	ベルトガード(上)カバー	BELT GUARD (TOP) COVER
13	6339	*	*	2	止めねじ	SCREW 1/8x44 L=4
14	13740	*	*	1	ねじ	SCREW 9/64X40
15	10650	*	*	1	ねじ	SCREW 3.4X36 L=6
16	13425	*	*	1	ベルトガード(組)	BELT GUARD COMPLETE
17	13427	*	*	2	支工	SUPPORTER
18	50099	*	*	2	ワッシャー	WASHER 5
19	14024	*	*	2	ねじ	SCREW 3/16X32 L=9.6
20	10561	*	*	2	ねじ	SCREW 5/32X40 L=6.5
21	11142	*	*	2	ワッシャー	WASHER 4
22	50103	*	*	2	ナット	NUT
23	15041	*	*	4	ボビン	BOBBIN
	15041	*	*	2	ボビン	BOBBIN
24	N0122	*	*	6	針	NEEDLE
	N0122	*	*	3	針	NEEDLE
25	8118	*	*	1	ドライバー(大)	SET SCREW 7/32X32 L=7
26	8120	*	*	1	ドライバー(中)	SCREW 13/64X32 L=16.5
27	8121	*	*	1	ドライバー(小)	WASHER
28	10747	*	*	1	六角レンチ(1/16インチ)	WRENCH
29	11487	*	*	1	六角レンチ(3ミリ)	WRENCH
30	11969	*	*	1	六角レンチ(2.5ミリ)	WRENCH
31	50285	*	*	1	メガネレンチ	DOUBLE HEAD WRENCH
32	10748	*	*	1	メガネレンチ	DOUBLE HEAD WRENCH
33	11193	*	*	1	油	OIL
34	8125	*	*	1	油差し	OILER
35	13079-A	*	*	1	チェーン	CHAIN
36		*	*	1	かぎ	HOOK
37	13094	*	*	1	ペダル	PEDAL COMPLETE
38	10947	*	*	1	系立てセット	THREAD UNWINDER COMPLETE (THREE)
		*	*	1	系立てセット	THREAD UNWINDER COMPLETE (TWO)
39	15101	*	*	1	系巻きセット	BOBBIN WINDER COMPLETE
40	8132-B	*	*	1	補用品袋	ACCESSORIES PACK
41	11196	*	*	1	ピンセット	TWEEZERS

**Consolidated Sewing
Machine Corp.**
Website: www.consew.com

MAIN office

131 W. 25th Street
New York, NY 10001
Tel: 212-741-7788
Fax: 212-741-7787
e-mail: consew@att.net

Miami, FL

4013 N.W. 79th Avenue
Miami, FL 33166
Tel: 305-471-0200
Fax: 305-471-0243
e-mail: miamisales@consew.com

Los Angeles, CA

2320 South Hill Street
Los Angeles, CA 90007
Tel: 213-745-8844
Fax: 213-745-8855
e-mail: lasales@consew.com